

Rexroth Pump (45cc) PSI Verification

(Hart-A-Gen Trouble-Shooting Technique)

Pump Burp

An effective way to verify a pump's performance (is it working or has it self-destructed?) is to disconnect the hose at the motor INLET. This is the high-pressure line from the pump. Place the end of the hose in a bucket. Jog the PTO by turning it on and off for 2-5 second intervals. The hose should belch fluid. If it does, this indicates the pump is working - - pumping fluid.

Pump Pressure Verification

The next step is to determine if the pump is capable of developing and holding pressure.



This procedure is done AT THE PUMP.

Using a pressure gauge (0 – 5,000 psi) arrangement similar to the photo on the left, **cap off the pump outlet** (high pressure side).

Fluid will flow from the pump case drain to the reservoir, back to the pump inlet. See the PSI Hydraulic Circuit schematic. This maintains a minimum flow - - about 0.75 gpm - - which keeps the pump operating properly.

Remove the cap cover from the **PRESSURE CONTROL** and loosen the jam nut. Back out the **Pressure Control adjustment screw** about $\frac{1}{2}$ " or more (till there is no spring tension).

DO NOT TOUCH THE FREQUENCY (FLOW) CONTROL!

Operate pump at 800-1200 RPM, depending upon KW size. Pressure should be about 600 psi.

Slowly screw in **PC adjustment screw** until 3500 psi exists. Lock down lock nut.

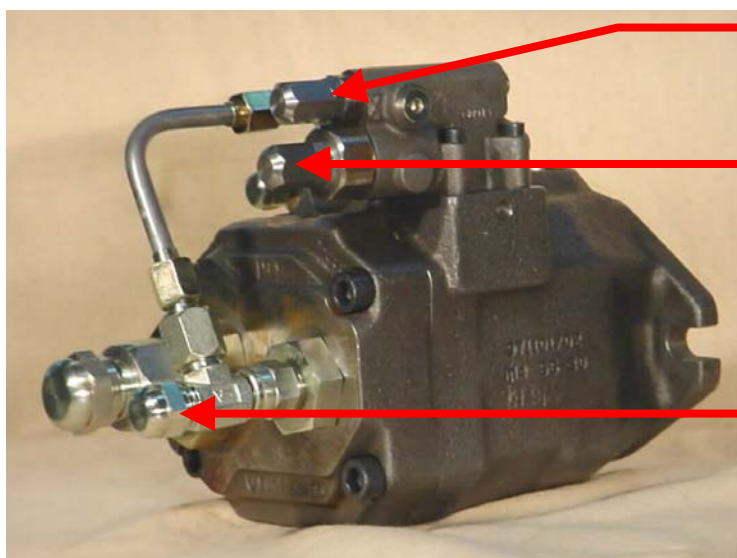

Frequency (flow) control

Pressure (KW) control

Pump OUTLET

(High Pressure)

If the pump was able to slowly increase the pressure, then the pump is operating properly.

If the pressure did not increase, then the pump is suspect.

If the pressure convulsed (was jerky), then the PTO (or transmission) is suspect.

PSI Hydraulic Circuit Schematic

Hart-A-Gen Basic Hydraulic Circuit

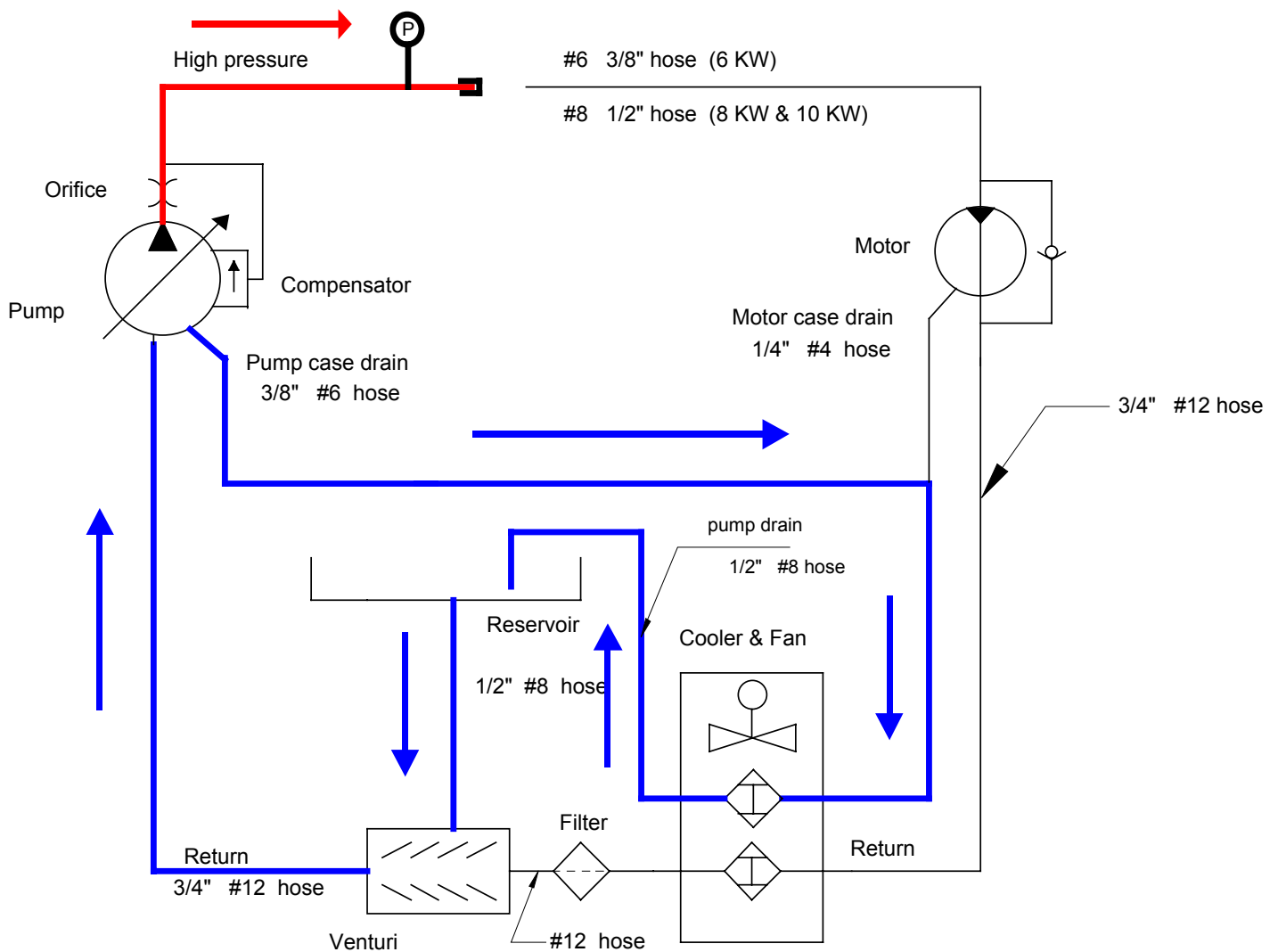

If the pump is pumping, when you place a resistance on that line - - a motor (or ball-valve) - - pressure will result. This normally eliminates the pump as being defective.

CAUTION: DO NOT CAP OFF THE HOSE END!

Capping off the end of the hose is the same as completely closing a ball-valve on that line. This can be accomplished on the Hart-A-Gen test stand, but you normally cannot shut down the PTO fast enough to avoid reaching 4,000 psi or higher - - - which will either damage the pump or burst the hose.